

والتش الذهب ٢٠٠٠

GOLD MONSTER 2000™

USER MANUAL

Multi-Au™
Gold Augmented Simultaneous Multi-Frequency

MINELAB

Contents

INTRODUCTION	3	DISCRIMINATION FEATURES	11
Technology	3	Gold Chance Indicator	11
VLF Sensitivity	3	Factors Affecting Accuracy	11
Multi-Au™	3	Target Identification Number	12
Echo Wave™ Audio	3	Factors Affecting Target ID	12
The Gold Monster 2000™ Experience	3	Gold Monster 2000 Audio	13
		Threshold Tone	13
		Detection Audio	13
		Echo Wave™ Audio [Default]	13
GETTING STARTED	4	Using the Discrimination Features	14
Quick Start	4	Tips for using Gold Monster 2000 Discrimination Features	14
Factory Default Settings	4		
Factory Reset	4		
Display & Controls	5		
Battery & Charging	6	ADVANCED CONCEPTS	15
Charging the Battery – Universal AC Charger	6	Identifying the Source of Detector Noise	15
Charging the Battery – Car Battery Charger Cable	6	Electromagnetic Interference (EMI)	15
Charge Status LED	6	Ground Noise	15
Battery Level Indication	6	Conductive Ground Noise	16
Automatic Shut-Down	6	Detector Sensitivity and Your Hands	16
Battery Maintenance	6		
Wired Earbuds	7	TROUBLESHOOTING	17
Connecting Wired Earbuds	7	Errors	17
		Coil Disconnect Error	17
		Low Battery Warning	17
		System Errors	17
		Coil Overload	17
		General Troubleshooting	18
FEATURES AND SETTINGS	8		
Automatic Noise Cancel	8	CARE & SAFETY	19
Sensitivity	8		
Manual Sensitivity	8	SPECIFICATIONS	20
Auto Sensitivity	8	General Specifications	20
Ground Type	9	Software Updates	20
Difficult [Default]	9		
Normal	9		
Benign	9		
Change the Ground Type	9		
Ground Balance	10		
Easy-Trak (Automatic Tracking)	10		
Quick-Trak	10		
Volume	10		

Introduction

The Gold Monster 2000™ is a Multi-Au™, simultaneous multi-frequency gold detector that provides extreme VLF sensitivity to small gold in all soils.

TECHNOLOGY

VLF Sensitivity

Gold Monster 2000 employs multiple frequencies between 12 and 75 kHz, (compared to a single frequency 45 kHz in the Gold Monster 1000) ensuring sensitivity to the widest range of nugget sizes, down to the very smallest (including below 0.01 g), often undetectable to other gold detectors.

Multi-Au™

Multi-Au™ is Minelab's simultaneous multi-frequency (Multi-IQ™) technology, purpose-built for gold detection. It builds on the Multi-IQ technology used in coin and treasure detectors, combining Multi-Frequency VLF operation with signal-processing techniques inspired by Pulse Induction (PI) technology. The result is exceptional ground balance across all soil types and improved discrimination that helps users distinguish gold from iron and hot rocks.

Echo Wave™ Audio

The all-new Echo Wave™ detection audio allows users to hear sensitive detection audio while simultaneously hearing Multi-Au driven discrimination tones, assisting users to distinguish gold from iron and hot rocks without loss of detection depth.

THE GOLD MONSTER 2000™ EXPERIENCE

The Gold Monster 2000 bridges the gap between single frequency VLF gold detectors and higher-performance gold detectors. With its Multi-Au™ technology and small coils, it is exceptional at finding shallow, ultra-fine gold.

Gold Monster 2000 users will experience a VLF gold detector that is capable of stable operation at very high sensitivity settings in any soil in the appropriate Ground Type setting. This is in contrast to single frequency VLF gold detectors, which operate well in soils with low mineralisation, but rapidly lose performance as soil mineralisation and conductivity increases.

Prospectors at historic gold mining sites will find hunted-out mullock heaps and tailings piles become productive again, with ultra-fine gold missed by other gold detectors now within reach with the Gold Monster 2000.

Artisanal miners will experience an ability to extract more small pieces of gold from excavated soil than with single frequency VLF detectors.

Beginner prospectors will experience a detector that is easier to learn and with a greater chance of finding gold in their first session than almost any other gold detector on the market.

Expert prospectors will find the Gold Monster 2000 an ideal complement to a high-end gold detector like GPX 6000 or GPZ 7000, as an aid to target pinpointing, for patch finding, or for detecting small nuggets often missed when excavating a larger, deeper nugget found with the primary detector.

With experience, users will find that the Gold Monster 2000 discrimination features can reduce time spent recovering junk targets, resulting in more productive hunts.

Users comparing the performance of the Gold Monster 2000 with other single frequency VLF detectors will see comparable or slightly better performance in extremely benign or very low mineralisation soils, and significantly increased performance in mineralised soils.



Getting Started

This section shows you how to quickly set up your detector to begin detecting with minimal adjustment and describes how to identify and adjust key detector functions.

QUICK START

 Before first use, it is recommended that you fully charge the battery [\(page 6\)](#).

 Before beginning Quick Start, restoring your detectors factory default settings is recommended.

You can manually adjust your detector to the settings listed in the following section "[Factory Default Settings](#)" or perform a Factory Reset as described in "[Factory Reset](#)".

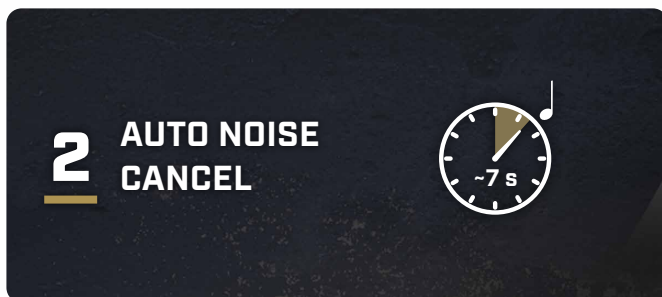
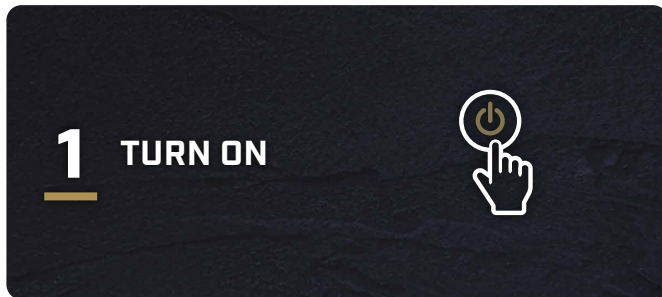



FACTORY DEFAULT SETTINGS

The factory default settings are optimised for detecting in almost all conditions. The settings are a practical choice for users who want to begin successfully detecting without the need to manually adjust detector settings.

Quick Start is best used with these factory default settings:

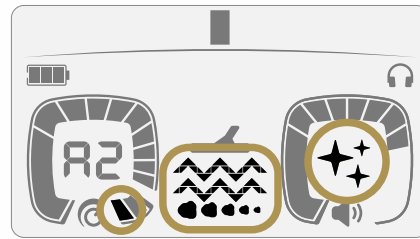
- Ground Type: Difficult
- Sensitivity: Auto 2
- Echo Wave™ Audio: On



 **NOTE:** The detector saves Sensitivity, Ground Type, Volume, and Echo Wave™ Audio settings when powered Off. However, if it's powered Off with the Ground Type set to Benign, then both the Ground Type and Sensitivity will revert to default upon restart. For best performance, use Normal or Difficult as they allow significantly higher sensitivity than Benign [\(page 9\)](#).

FACTORY RESET

Factory default settings can be restored at any time by conducting a factory reset.

1. Ensure the detector is powered Off.
2. Press-and-hold the Power button until *FP* appears on the Target ID Display (approximately 7 seconds).

FP

FP appears on the Target ID Display when Factory Presets are restored.

3. Release the button. Automatic Noise Cancel will begin when Factory Reset is complete.

Getting Started *(Continued)*

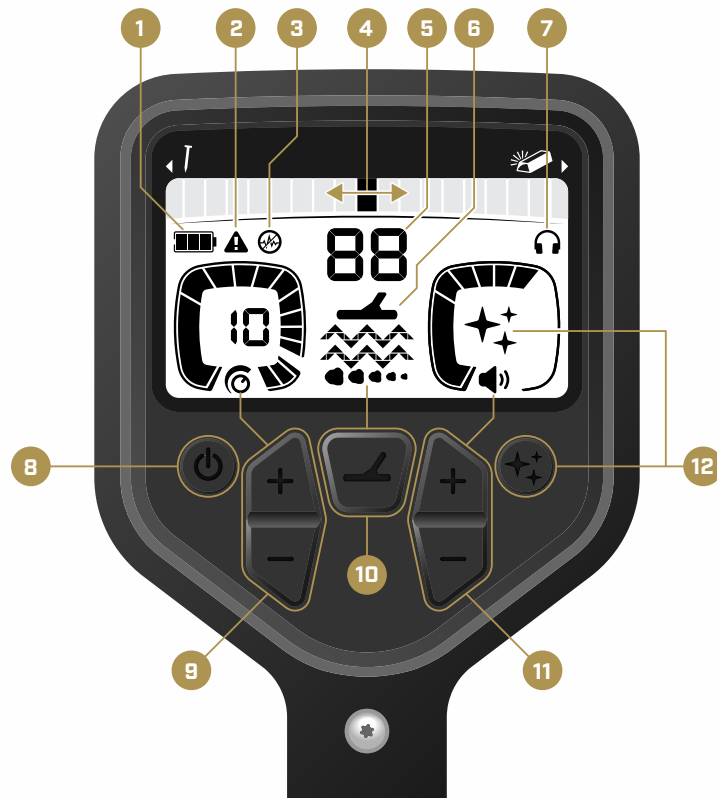

DISPLAY & CONTROLS

1. BATTERY LEVEL

Indicates the current battery level [page 6].

2. ERROR

Is displayed when there is an error: Coil Disconnected, System Error, Low Battery, and Coil Overload [page 17].

3. AUTO NOISE CANCEL

Flashes during start-up Auto Noise Cancel [page 8].

4. GOLD CHANCE INDICATOR

Estimates the likelihood that a detected target is non-ferrous or ferrous [page 11].

5. TARGET ID NUMBER

A numerical value [from 00 to 99] assigned to detected targets based on their conductivity [page 12].

6. QUICK-TRAK INDICATOR

Flashes during Quick-Trak [page 10].

7. HEADPHONES

Displayed when wired headphones are connected [page 7].

8. POWER

Press to turn the detector On/Off.
Long-press (7 seconds) from Off to restore factory settings [page 4].

9. SENSITIVITY LEVEL

Press to adjust the Sensitivity Level, Manual 1–10, Auto 1 and Auto 2 [page 8].

10. GROUND TYPE / QUICK-TRAK

Short-press: Cycle to next the Ground Type [page 9]
Press and hold: Quick-Trak [page 10]

11. VOLUME LEVEL

Press to adjust the Volume Level [1–12] [page 20].

12. ECHO WAVE™ AUDIO

Press to toggle between Detection Audio and Echo Wave™ Audio [page 13].

Getting Started *(Continued)*

BATTERY & CHARGING

The Gold Monster 2000 is supplied with two removable lithium-ion rechargeable batteries.

⚡ Beginning each detecting session with a fully charged battery is recommended.

The Gold Monster 2000 battery can be charged using the supplied charging methods:

- The supplied universal AC plug pack (100 to 240 V AC)
- Typical 12 V DC car or truck systems using the supplied direct battery connection clips.

⚠ CAUTION: Only charge the detector in ambient temperatures between 0°C and +40°C (+32°F and +104°F).

The charge time from completely flat to 100% is approximately 3.5 hours.

Charging the Battery – Universal AC Charger

1. Connect the AC charger plug pack to a powered wall outlet.
2. Plug the charging connector into the charging socket on the battery.
3. The battery charging status LED will flash green during charging. When charging is complete, the charge status LED will remain steady on green.

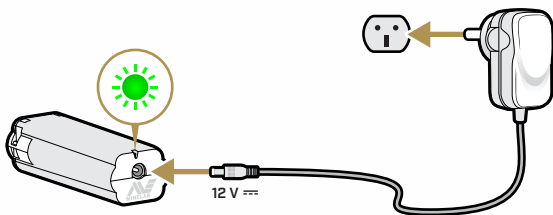

Charging the Battery – Car Battery Charger Cable

1. Attach the black negative [-] clip to the negative [-] vehicle battery terminal.
2. Attach the red positive [+] clip to the positive [+] vehicle battery terminal.
3. Plug the charging connector into the charging socket on the top of the battery.
4. The battery charging status LED will flash green during charging. When charging is complete, the charge status LED will remain steady on green.

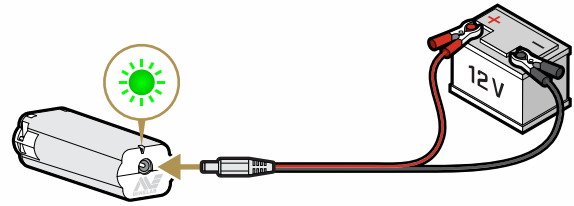

Charge Status LED

- ⚡ Charging (flashing)
- Fully charged (on)
- Error

Battery Level Indication

The Battery Level indicator shows the current battery level.

 The Battery Level Indicator (fully charged state shown)

ⓘ NOTE: The detector regulates the battery voltage so that detector performance remains constant regardless of the battery level.

Automatic Shut-Down

When the battery level is critically low, *bL* will appear on the Target ID Display and the Battery Level Indicator and Error Indicator will flash. The detector will then shut down automatically.

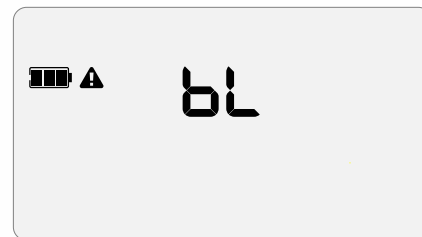

Battery Maintenance

Lithium-ion battery performance may degrade if unused for long periods of time. Fully charge the battery at least once every 3 to 4 months to prevent this from occurring.

Even with correct care and maintenance, Lithium-ion battery performance reduces over time with normal use. Therefore, the battery may need to be replaced every few years.

Getting Started *[Continued]*

WIRED EARBUDS

The Gold Monster 2000 is supplied with wired 3.5 mm (1/8-inch) earbuds.

Any standard 3.5 mm (1/8 in) headphones or earbuds can be connected to Gold Monster 2000, provided that the headphone connector overmold is less than 9 mm (0.35 in) in diameter. If it is larger, the connector will not fit inside the socket.

! NOTICE: When headphones are not in use, make sure that the waterproof dust-cap on the rear of the Control Pod is screwed firmly into place.

Connecting Wired Earbuds

1. Unscrew the plastic dust-cap from the Headphone Socket on the rear of the Control Pod. If it is tight, it can be loosened with a small coin.

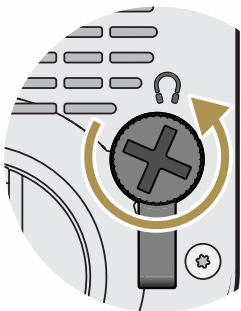

2. Plug the earbuds into the Headphone Socket.

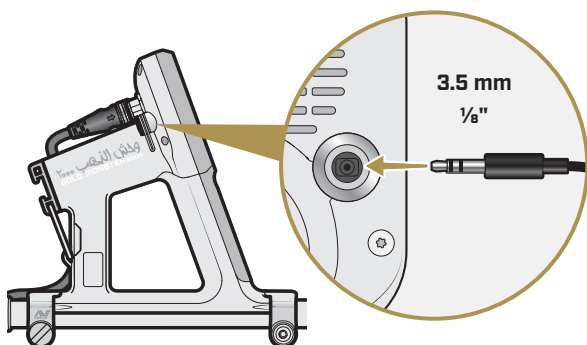

The headphones icon  will appear on the LCD.

Features and Settings

AUTOMATIC NOISE CANCEL

Gold Monster 2000 has an Automatic Noise Cancel process that occurs every time the detector is powered on. It adjusts the operating frequencies of the detector to minimise noise from Electromagnetic Interference (EMI).

For best results, hold the coil stationary, just above the ground until Automatic Noise Cancel is complete. Progress is shown on the Gold Chance Indicator and the Noise Cancel Indicator will flash.

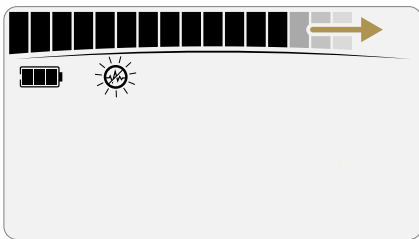

TIP: If the audio responses become erratic due to EMI, turn the detector off and then on again to initiate an Automatic Noise Cancel.

SENSITIVITY

Gold Monster 2000 offers both Manual and Automatic sensitivity, giving users the flexibility to choose their preferred level of control.



The Sensitivity level is displayed on the Sensitivity Numerical Display.

The Sensitivity is adjusted using the Sensitivity +/- buttons .

Manual Sensitivity

If setting Sensitivity manually, increase the Sensitivity so that you can hear a comfortable level of audible noise. When detecting, listen for repeatable fluctuations in the audible noise that indicate the presence of small gold nuggets.



Auto Sensitivity

Auto Sensitivity has higher resolution than Manual Sensitivity—if the optimal sensitivity is somewhere between Manual Sensitivity settings 9 and 10, Auto Sensitivity can select a level between these settings.

When an Auto setting is selected, A1 or A2 is displayed for 3 seconds, followed by the Auto Sensitivity Level selected by the detector (1–10).

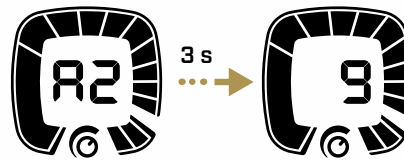

In both Auto settings, the detector monitors the ground noise from the soil during normal detecting and adjusts to the highest usable sensitivity level.

The Sensitivity Numerical Display continuously updates to show the current Auto Sensitivity level.

TIP: Auto Sensitivity determines the best sensitivity setting for all Ground Type settings. It will automatically adjust for the new Ground Type setting when changed.

Auto 1

Auto 1 uses lower sensitivity setting for minimal ground noise.

Auto 2 (Default)

Auto 2 uses higher, more aggressive sensitivity setting for users who can tolerate a little more ground noise.

TIP: Auto 2 can be used determine the best Ground Type to use. See the Tip on [page 8](#).

Features and Settings *(Continued)*

GROUND TYPE

Ground Type controls the amount of unwanted ground noise that is removed from the audio response.

There are three Ground Type settings: Difficult (default), Normal and Benign.

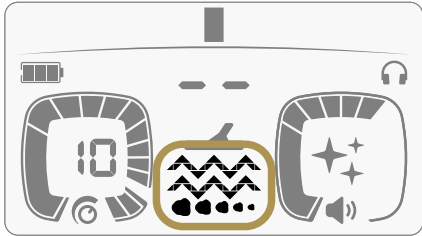

Difficult *(Default)*



Difficult is perfect for any soils, including highly mineralised or salt-conductive soils.

This Ground Type remains stable at the maximum Sensitivity setting in almost any soil, while detecting ultra-fine gold nuggets undetectable to any other detector. This default setting will give best performance in most conditions.

This Ground Type also has the best hot-rock rejection and the lowest sensitivity to charcoal. This Ground Type is also the least sensitive to the natural electrical charge of your body, which highly sensitive metal detectors can detect. This is relevant if you wave soil or targets over the coil by hand.

Normal

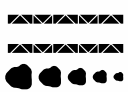

Normal is good for mineralised soils without salt-conductive or wet soil conditions. This

Ground Type has slightly better sensitivity to ultra-fine nuggets than Difficult in the absence of salt-conductive soils.

Noisy detection audio or reduced sensitivity settings are an indication that Difficult is a better setting for the conditions. Use Normal if the detector is completely stable at maximum sensitivity in this setting.

Benign

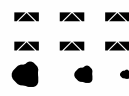

Benign is a VLF-style Ground Type which performs similarly to the Gold Monster 1000 single-frequency gold detector. While this setting may seem sensitive, it can become unstable in even mildly mineralised soils and is therefore only recommended for *extremely* benign soil conditions.

In most soils, Normal or Difficult will give better depth on targets in-ground. Noisy detection audio or reduced sensitivity settings are an indication that Normal or Difficult is a better setting for the conditions.

Only use Benign if the detector is completely stable at maximum sensitivity in this Ground Type.





NOTE: When the detector is powered Off with the Ground Type set to Benign, the Ground Type and Sensitivity will reset to default on restart [page 4].

Change the Ground Type

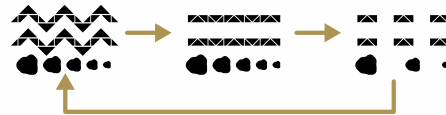
Press the Ground Type button  to cycle to the next Ground Type setting.



TIP: Using the Auto 2 Sensitivity setting is the best way to determine the best-performing Ground Type setting for a given location. To do this:

1. Press the Sensitivity +/- buttons  to set the Sensitivity Level to Auto 2.
2. Detect over the soil for at least 20 seconds. You can continue for longer for even more accurate results, however it's not essential.
3. Press the Ground Type button  to cycle through Difficult, Normal, and Benign. Select the one that displays the highest Auto 2 Sensitivity level.

Features and Settings *(Continued)*

GROUND BALANCE

The Ground Balance function calibrates the detector to the local soil to eliminate false signals caused by soil mineralisation. Ground Balance, enhanced by Multi-Au technology enables stable detector operation over the widest range of soil types. There are two Ground Balance methods; Easy-Trak, which is automatic, requires no user input and is the recommended Ground Balance method, and Quick-Trak for faster results but requires user interaction.

Easy-Trak (Automatic Tracking)

As a true automatic detector, the Gold Monster 2000 tracks automatically to the ground to continuously remove ground noise. Easy-Trak provides fast, reliable ground balancing for a seamless detecting experience, without tracking out targets.

Easy-Trak is relatively fast and will track to any soil in less than 5 seconds. It may take slightly longer in the Benign Ground Type setting in some soils.

Easy-Trak can effectively track out many hot rocks, making this another way to identifying hot rocks (in addition to the discrimination features).

Some large junk targets may disturb the Easy-Trak ground balance briefly, however it will recover quickly once returned to clear soil.

NOTE: Easy-Trak updates the Ground Balance for all Ground Type settings simultaneously. You do not need to manually re-Ground Balance after changing the Ground Type.

Quick-Trak

Quick-Trak is a rapid ground balance feature that tracks to the ground faster than Easy-Trak, so is popular with users who feel that the automatic tracking is too slow in their particular soil conditions.

For most users however, Quick-Trak will rarely be required because Easy-Trak is fast and effective for all soils.

To initiate a Quick-Trak, press-and-hold the Ground Type button  while raising and lowering the coil between 10 and 100 mm above the ground. Continue for around 5 seconds or until the ground response is audibly diminished, then release the button.

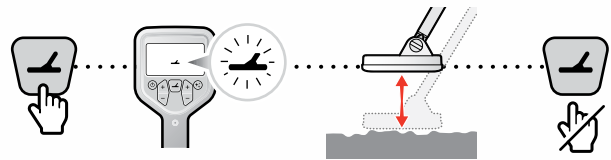

VOLUME

Press the Volume +/- buttons  to adjust the volume of all audio including system tones, detection and discrimination tones, and the Threshold Tone [\(page 13\)](#).

The Volume setting ranges from 1 (quietest) to 12 (loudest) with a default setting of 6.

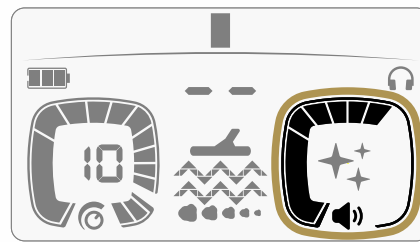

Discrimination Features

Gold Monster 2000 has discrimination features to assist the user in more quickly determining the chance that a detected target is gold or an unwanted target.

GOLD CHANCE INDICATOR

The Gold Chance Indicator displays the detector's estimate of the likelihood that a detected target is either non-ferrous (and potentially gold), or ferrous (iron or a hot rock). The estimate is based on the characteristics of the signal received from both the target and the surrounding soil.

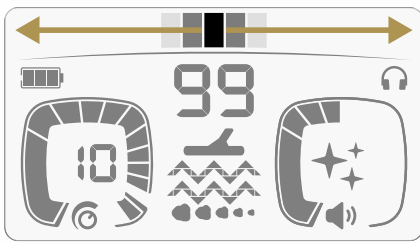

The Gold Chance Indicator fills in a centre-to-left, or centre-to-right direction.

When the Gold Chance Indicator bar fills to the right, the detection is more likely non-ferrous (and possibly gold). The more bars displayed to the right, the higher the likelihood that the target is non-ferrous.

When the Gold Chance Indicator bar fills to the left, the detection is more likely ferrous (either iron or a hot rock). The more bars displayed to the left, the higher the likelihood that the target is ferrous.

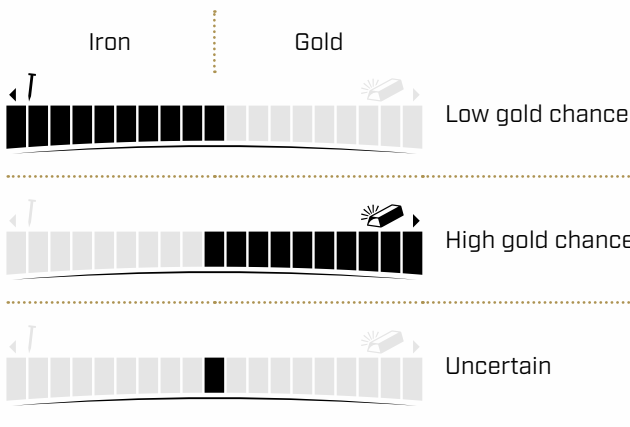

Factors Affecting Accuracy

The Gold Chance Indicator takes both the target signal response and the ground noise from the soil into account.

In mineralised ground, soil noise mixes with target signals, reducing the detector's confidence in identifying whether a target is ferrous or non-ferrous. As a result, the Gold Chance Indicator may show fewer bars, especially when the target signal is weak.

In weakly mineralised soil, the detector has greater confidence in distinguishing between ferrous and non-ferrous targets. It will typically display more bars on the Gold Chance Indicator, particularly when the target signal is strong.

Where the target signal is weak (because it is a small target, or a deeper target) and/or in soil that presents more ground noise, the detector may not have enough information to determine the chance that a particular target is ferrous or non-ferrous. In these cases, the detector may not display a gold chance indication or may display an indication that fluctuates left or right as the estimate is uncertain. As the target is being dug, and rechecked when closer to the coil, the gold chance indications will usually become more reliable.

The Gold Chance Indicator continuously measures ground noise, so its accuracy improves as you swing the coil over the target, allowing the detector to gather more data. Swinging over the target five or more times can provide a more accurate gold-chance estimate.

Discrimination Features *(Continued)*

TARGET IDENTIFICATION NUMBER

When a target is detected, the detector assigns a Target Identification (Target ID) number to it based on its conductive properties. The Target ID is displayed for five seconds, or until another target is detected.

Target ID numbers range from 00 to 99.

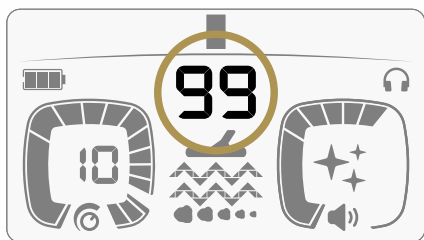

A Target with ID 99 displayed on the Target ID Display.

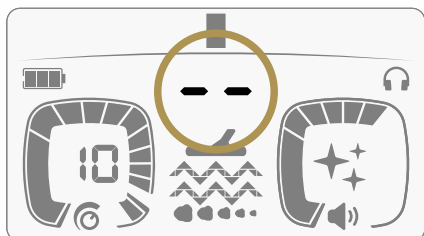

When there is no detection, two dashes are displayed.

Factors Affecting Target ID

The conductivity properties of a detected target depend mainly on the size, shape, and material properties of the target. For example, a very small, thin gold flake might have a Target ID of 00 or 01, but a large, thick silver coin might have a Target ID in the 85–95 range.

Below are the Typical ID ranges of common targets:

00	Salt Conductivity, Charcoal
00-15	Small Gold nuggets, foil, lead shot, small iron fragments
10-40	Medium gold nuggets, iron trash, small coins, hot rocks
40-99	Large gold nuggets, large iron trash, larger coins

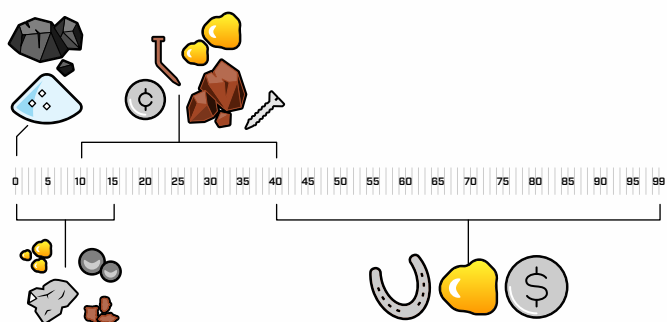

Target IDs do not contain any information about whether the target is ferrous or non-ferrous – that information is provided by the Gold Chance Indicator.

Target ID is an extra piece of information that can be used in conjunction with the Gold Chance Indicator, Echo Wave™ Audio, the detection audio response, and the user's knowledge of the site, to decide whether to spend time recovering the target.

Gold nuggets can potentially show at any Target ID number depending on size and shape, but smaller nuggets with very low Target IDs tend to be more common than large nuggets. Target IDs above 30 could be large gold nuggets, but depending on the site, may be more likely to be large trash targets. Certain trash targets tend to give consistent recognisable Target IDs (e.g. lead shot, foil fragments or hot rocks at some sites), which can help users more quickly identify the target. In all cases, user knowledge of the site, the types of gold that may be present, and the type and prevalence of trash targets are critical to make best use of Target IDs.

Discrimination Features *(Continued)*

GOLD MONSTER 2000 AUDIO

Gold Monster 2000 has two types of audio: Echo Wave™ Audio and Detection Audio.

Press the Echo Wave™ Audio button  to toggle Echo Wave™ Audio On/Off.

Threshold Tone

Before describing the two audio types, it's worth noting that both share a Threshold Tone, which is a constant background hum that helps make faint target signals easier to hear and can assist in setting the optimum sensitivity level.

Gold Monster 2000 uses a highly sensitive, true threshold tone, similar to those used in high-performance gold detectors, to ensure even the smallest targets are detectable.

Because the human ear is more responsive to subtle variations in a continuous tone than to sounds that start from silence, a threshold tone makes faint gold easier to hear.

Detection Audio

The pitch and volume of the Detection Audio response vary continuously according to the signal strength (or depth) of the target. Detection Audio is an All-Metal audio response, which generates detection audio for both non-ferrous and ferrous targets.

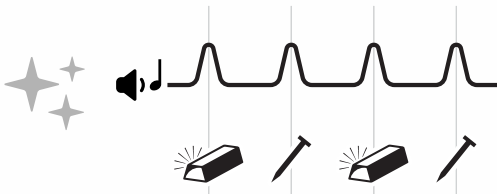

Echo Wave™ Audio *(Default)*

Echo Wave™ Audio is the default audio type for the detector and is designed for general detecting. It combines Detection Audio with some of the audio characteristics of coin and treasure detectors to provide extreme sensitivity to ultra fine gold, while simultaneously providing useful discrimination information.

Echo Wave™ Audio superimposes distinctive discrimination tones onto the Detection Audio so that the user can hear both simultaneously. A unique high tone indicates probable non-ferrous targets (potentially gold). A distinctive low tone indicates probable ferrous targets (iron or hot rocks).

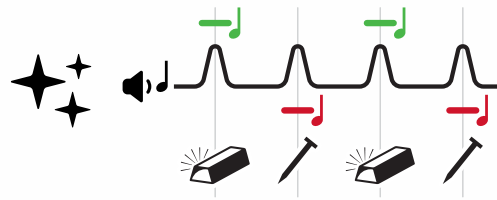

Echo Wave™ Audio allows users to have extreme sensitivity to small gold, while at the same time hearing discrimination information on the target with no loss of sensitivity.

Discrimination Features *(Continued)*

USING THE DISCRIMINATION FEATURES

Although the Gold Monster 2000 discrimination features share similarities with those used in coin and treasure detectors, they are designed differently to suit the typical conditions of gold detecting.

Gold nuggets tend to be found more often at sites with relatively sparse trash targets, moderate to high levels of soil mineralisation, and are usually much rarer and smaller in size than coins and relics. In these conditions,

the discrimination properties of targets are much more difficult to determine, and maximising finds depends more on detecting and digging as many potential gold nugget targets as possible, rather than masking as many potentially ferrous targets as possible. Discrimination features in the Gold Monster 2000 are therefore aimed at providing extra information to the user about detected targets, rather than masking targets at the risk of masking small gold.

Tips for using Gold Monster 2000 Discrimination Features

- ✓ Dig every target while learning the detector – paying attention to the behaviour of the Target IDs, Gold Chance Indicator, and Echo Wave™ Audio. With experience, users will learn how to correctly interpret the indications to maximise the chance of finding gold.
- ✓ The discrimination indications are a guide only and can be affected by mineralised ground, especially for small or deep targets. If in doubt, always dig the target.
- ✓ Use the information from the Detection Audio, Echo Wave™ Audio, Gold Chance Indicator and Target ID in combination – each provides a slightly different view of the target characteristics and are most effective when used together.
- ✓ Very small (or deep) gold will often give no Echo Wave™ or Gold Chance Indication, or may give mixed indications. Always dig targets like this, especially if they have a low Target ID number, indicating a small target—it could be fine gold. Some ultra-fine gold nuggets may not give solid Echo Wave™ or Gold Chance indications until on the surface or in the scoop.
- ✓ Gold Nuggets in mineralised ground will often give mixed Echo Wave™ and Gold Chance Indications. Always dig targets like this.
- ✓ Rechecking a target after starting to dig can give better discrimination indications, as the coil gets closer to the target. A detection with mixed Echo Wave™ tones and Gold Chance indications that starts to give more high tones and Gold indications after clearing the top half-inch of soil is likely to be non-ferrous, possibly gold.
- ✓ Conversely, a detection with mixed Echo Wave™ tones and Gold Chance indications that starts to give more Echo Wave™ low tones and 'Iron' Gold Chance indications after clearing the top half inch of soil is more likely to be a hot rock or iron.
- ✓ Detectable hot rocks tend to be close to the surface and usually give strong ferrous Gold Chance Indications and Echo Wave™ low tones and usually have Target IDs above 10. With some experience, these can usually be quickly identified.
- ✓ At some sites, particularly common non-ferrous trash targets will give consistent Target IDs and can be easily identified – lead shot and foil are good examples. Care should be taken if deciding not to dig targets like this, as gold can sometimes come in at the same Target IDs.

Advanced Concepts

IDENTIFYING THE SOURCE OF DETECTOR NOISE

When detecting, there are generally three types of noise that can be heard depending on the detector settings, detecting location, or other factors. Accurately identifying the type of noise you are experiencing will help you to apply the correct solution.

Note: In either Automatic Sensitivity setting, the detector will attempt to automatically compensate for noise from interference, therefore identifying the source of interference is best done using a Manual Sensitivity setting.

Electromagnetic Interference (EMI)

EMI can originate from many sources. The most obvious are power lines, electric fences, electric motors, transformers, radio transmitters and mobile (cell) phones. Most EMI is generated by human activity, though distant lightning strikes are also a source of EMI.

Identifying EMI

EMI is easy to identify because it is the only source of noise that is present when the coil is stationary. To verify that noise is due to EMI, hold the coil stationary, and away from metal objects to see if the noise remains.

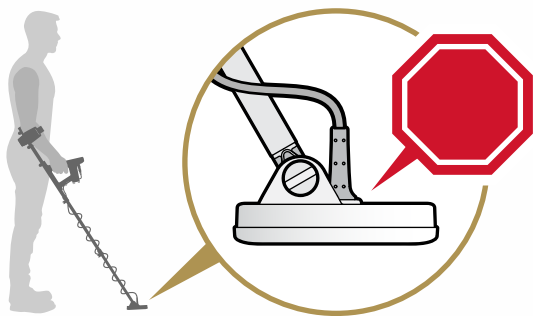

Managing EMI

To manage EMI, turn the detector off and then on again to prompt an Automatic Noise Cancel [\[page 8\]](#).

Ground Noise

Ground noise is present when the metal detector interprets the ground as being a target due to the mineral content of the ground, and can be categorised as the following:

- **Benign** — Ground with little or no mineralisation.
- **Normal** — Ground with low levels of mineralisation.
- **Difficult** — Ground that has medium to high, or variable levels of mineralisation.

Identifying Ground Noise

To identify ground noise, raise and lower the coil above the ground a couple of times from 10 to 100 mm (½ to 4 in). If you hear signals that correlate with the coil movements, and the signals stop when the coil is stationary, then it is ground noise.

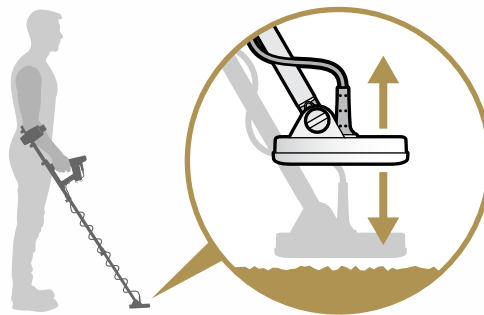

Managing Ground Noise:

- Change the Ground Type Normal or Difficult [\[page 9\]](#).
- If required, perform a Quick-Trak Ground Balance [\[page 10\]](#)

Advanced Concepts *(Continued)*

Conductive Ground Noise

Conductive soils commonly occur when the soil contains salts. The effects of conductivity are most noticeable after rain when salts are dissolved in water and become conductive. Ground may be conductive (salty) without any obvious environmental signs. If a detector is sensitive enough to detect small gold, then it is also likely to detect low levels of conductivity.

Identifying Conductive Ground Noise

To verify that noise is due to conductive ground, hold the coil 1 metre (3.3 feet) or higher above the ground. Tilt the coil so that it is parallel to the ground (horizontal) and then raise and lower the coil in the air between knee and shoulder height. If you hear noise that correlates to the coil movement, then noise is likely due to conductivity in the ground.

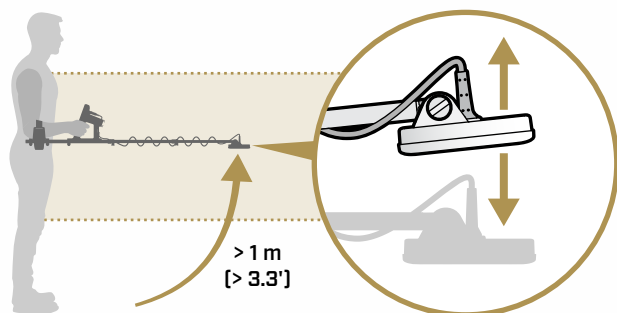

Managing Conductive Ground Noise:

Select the Difficult Ground Type setting ([page 9](#)).

Detector Sensitivity and Your Hands

Since the GOLD MONSTER 2000 operates at up to 75 kHz, it can be sensitive to your hands, which may act like a target at this frequency because the human body is slightly conductive. To avoid this, use a plastic prospector's scoop when recovering targets, or switch the Ground Type to Difficult when waving targets over the coil by hand.

Troubleshooting

ERRORS

Some detector faults will display an Error indication on the Display. Try the recommended actions listed before contacting an Authorised Service Centre.

Coil Disconnect Error

Cd is displayed in the event of a Coil Disconnect Error, along with a flashing Ground Balance Coil indicator and Error Indicator. In the event of a Coil Disconnect Error, the detector will shut down after 30 seconds.



In the event of a Coil Disconnect Error, follow these steps:

1. Check that the coil connector is connected properly at the back of the Control Pod.
2. Check the coil connector pins on the back of the Control Pod for any damage
3. Check the coil cable for damage.
4. Check the coil for visible signs of damage.
5. Try another coil, if you have one available.

Low Battery Warning

When the battery level is critically low, *bL* will appear on the Target ID Display. The detector will shut down 30 seconds after reporting a Low Battery Error.

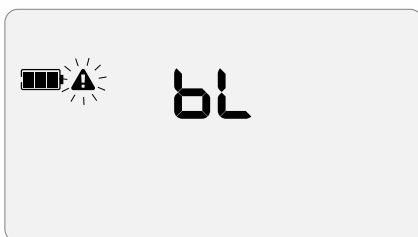

In the event of a Low Battery Error, follow these steps:

1. Replace the battery with a fully charged battery.
2. Recharge the battery.

System Errors

In the event of a System Error, *Er* will be displayed along with a flashing Error indicator. The detector will shut down 5 seconds after reporting a System Error. In the event of a System Error, the detector will shut down after 30 seconds.

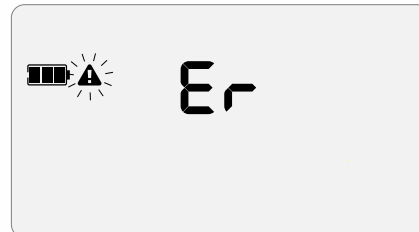

In the event of a System Error, follow these steps:

1. Restart the detector to determine if the error remains.
2. Confirm the coil is attached correctly.
3. Perform a Factory Reset [\[page 4\]](#).
4. If the error remains, return the detector to your nearest Authorised Service Centre for repair.

Coil Overload

Very large metal objects close to the coil may overload the detector electronics. If this occurs, *OL* will be displayed, along with a flashing coil icon and error indicator, and an alarm tone will repeat until the coil is moved away from the source of the overload.



Overloading is not harmful to the electronics of the detector.

Troubleshooting *(Continued)*

GENERAL TROUBLESHOOTING

Try the recommended actions listed, in order, before contacting an Authorised Service Centre.

Detector does not turn On, or turns Off by itself

1. Check that the Coil is connected.
2. Check that the battery is properly seated inside the battery compartment, with contacts correctly orientated with respect to the battery springs.
3. Replace the Battery.
4. Charge the Battery.
5. Check that the Battery is charging and the green Charge Status LED is flashing or Solid Green if fully charged.

Erratic and/or excessive noise

1. Move away from local sources of Electromagnetic Interference (EMI).
2. Restart the detector to initiate an Auto Noise Cancel.
3. Reduce the Sensitivity Level.

No sound – Wired Earbuds

1. Check that the detector is On, and start-up has completed.
2. Check that the headphones are plugged in and fully inserted into the headphone socket.
3. Check that the headphones indicator is displayed on the LCD.
4. Check that Volume is set to an audible level.
5. Unplug the headphones and confirm that the detector speaker is audible.
6. Check that the headphones connector is free of moisture or debris.
7. If available, try using a different set of earbuds or headphones.

Headphone indicator is On, but no headphones are connected

There may be water inside the Headphone Socket causing false detection of wired headphones.

1. Check that the Headphone Socket is clear of water and obstructions.
2. If water is present, use a warm (not hot) air dryer to dry the Socket.

Detector does not operate after being left in an extremely hot environment (e.g., back seat of a car on a sunny day)

The detector has overheated. It may briefly power On and display *bL* before freezing.

1. Place the detector in a cool, dry location and allow it to cool down.
Once it has cooled sufficiently, normal operation will resume.

Detector shafts are slipping under light load, or do not lock tightly

1. Open the shaft Camlocks.
2. Gently tighten the thumbscrew in small increments
3. Close the camlock.
4. Check after adjustment by applying normal force to the Shafts.
5. Repeat until the Shafts do not collapse easily under normal force.

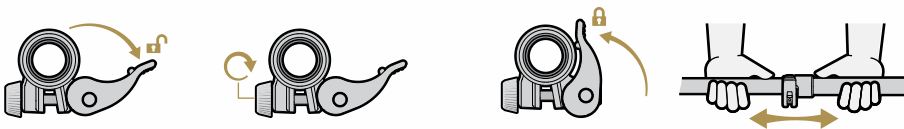

Care & Safety

- Do not submerge the Control Pod in water – it is rain-proof only.
- The coil is waterproof to 1 metre (3.3 feet); however, care must be taken to ensure the Control Pod is not submerged.
- **⚠ WARNING:** Do not allow small children to play with the detector or accessories, small parts are a choking hazard.
- Wash your hands before handling the detector after using sunscreen or insect repellents.
- The Display lens is made from quality optical plastic for clear viewing of the screen and is therefore prone to scratching or serious damage if not treated with due care.
- Never clean the Display lens using solvent or alcohol-based cleaners. To clean the Display lens, use a slightly damp cloth with mild soap detergent. Dry with a clean lint-free cloth to remove water-spots.
- Do not use any lubricants, sealants, or solvent-based or alcohol-based cleaners on any part of your detector. Even chemicals typically considered mild such as isopropyl alcohol or silicone lubricants can degrade material properties or the integrity of seals. To clean, use a slightly damp cloth with mild soap detergent.
- Do not apply any chemicals including O-ring lubricant, grease or silicone grease to seals or O-rings if replacing the battery, as this may damage the battery seal, and may trap sand or debris causing further wear.
- Do not allow the detector to come into contact with gasoline/petrol or other petroleum-based liquids.
- Do not bring the detector or accessories into contact with sharp objects as this may cause scratches and damage.
- Avoid getting sand and grit in any moving parts including the Shafts, Camlocks, Yoke assembly, Battery housing and Battery Cap seal area. If sand and grit accumulate in these parts they should be carefully wiped down. The Shafts, Camlocks and Yoke assembly may be rinsed with fresh water and dried thoroughly.
- Do not expose the detector to extreme temperature conditions. The storage temperature range is from -20°C to +80°C (-4°F to +176°F). Avoid leaving it inside a vehicle parked in the sun on a hot day, as temperatures can reach extreme levels. If the detector has been exposed to high temperatures, allow it to cool down before attempting to power it On.
- Ensure the Coil Cable is kept in good condition, free of strain, kinks and tight bends.
- Do not expose accessories not listed as waterproof to liquid/moisture.
- Only charge the detector and accessories according to the instructions provided.
- Do not charge the battery in extreme temperature conditions – Only charge the detector in ambient temperatures between 0°C and +40°C (+32°F and +104°F).
- Do not use tools to tighten the Coil Connector to the Control Pod, this will damage the Control Pod. If the Coil Connector is not fitting easily, clean any dirt/grit away before trying again.
- Do not poke sharp objects into the Speaker grille to clean it, this will damage the Speaker and compromise the rainproof sealing.
- Disconnect the coil before packing/storing as luggage for transportation.

Specifications

GENERAL SPECIFICATIONS

Ground Type	Difficult Normal Benign
Ground Balance	Auto (Easy-Trak) Manual (Quick-Trak)
Noise Cancel	Automatic (on start-up)
Sensitivity	Manual 1-10 Auto 1 Auto 2
Volume	12 levels
Discrimination	Gold Chance Indicator
Target IDs	0-99
Echo Wave™ Audio	High tone (Gold) Low tone (Hot rocks/Iron)
Detector Length	65 cm-138 cm (25.6-54.4 in)
Detector Weight	1.25 kg (2.75 lbs) (including battery, with 5 in coil)
Display	Monochrome LCD
Audio Output	Internal speaker Wired 3.5 mm (1/8 in) earbuds
Coil Standard	GM2000-05 (5 in Round Double-D coil)
Waterproof rating	Control Pod: Rainproof, IP55-rated Coil: Waterproof, IP68-rated up to 1 m (3.3 ft)
Battery Options	2 × rechargeable 2700 mAh lithium-ion batteries
Battery Runtime	8 hours (approximately)
Battery Charge Time	3.5 hours (approximately)
Operating Frequency Range	12 to 75 kHz
Operating Temperature Range	0°C to +70°C (+32°F to +158°F)
Storage Temperature Range	-20°C to +80°C (-4°F to +176°F)
Battery Charging Temperature Range	0°C to +40°C (+32°F to +104°F)
Key Technologies	Multi-Au™ Echo Wave™ Audio

Minelab reserves the right to make changes to the design, equipment and technical features at any time. For the most up-to-date specifications for your detector, visit www.minelab.com.

SOFTWARE UPDATES

Gold Monster 2000 contains software that can be updated via a USB charging/data transfer cable. Visit www.minelab.com/product-manuals for up-to-date Gold Monster 2000 Software and installation instructions.

DOCUMENT USAGE RIGHTS

This work is licensed under the Creative Commons Attribution-NonCommercial-NoDerivatives 4.0 International (CC BY-NC-ND 4.0) International License. To view a copy of this license, visit: <http://creativecommons.org/licenses/by-nc-nd/4.0/>



DISCLAIMER

The Minelab metal detector described in this instruction manual has been expressly designed and manufactured as a quality metal detector and is recommended for treasure and gold detecting in non-hazardous environments. This metal detector has not been designed for use as a mine detector or as a live munitions detection tool.

MINELAB®, Echo Wave™, GOLD MONSTER®, GOLD MONSTER 1000®, GOLD MONSTER 2000™, GPX 6000®, GPZ 7000®, Multi-Au™ and Multi-IQ™ are trademarks of Minelab Electronics Pty. Ltd.

COMPLIANCE

Refer to the included *Instructions and Safety Information* leaflet for further regulatory information.



Minelab Electronics,
PO Box 35, Salisbury South,
South Australia 5106



www.minelab.com

4901-0537-EN-1

